



Novo modelo de recuperador para aquecimento central

Modelo C-80 HIDRO	Modelo C-100 HIDRO
	
<p>Quantidade de água: 50% superior!</p> <p><u>Novo modelo: 69,8 Litros</u> Modelo antigo: 46,7 Litros</p>	<p>Quantidade de água: 50% superior!</p> <p><u>Novo modelo: 85,3 litros</u> Modelo antigo: 55,4 Litros</p>
<p>Consumo e prestações: 80% rendimento</p> <p>Consumo/hora:</p> <p>Com 4 Kg de lenha: 16 kW Com 6 Kg de lenha: 24 kW</p>	<p>Consumo e prestações: 85% rendimento</p> <p>Consumo/hora:</p> <p>Com 6 Kg de lenha: 24 kW Com 8 Kg de lenha: 32 kW</p>



Modelo C-80 HIDRO

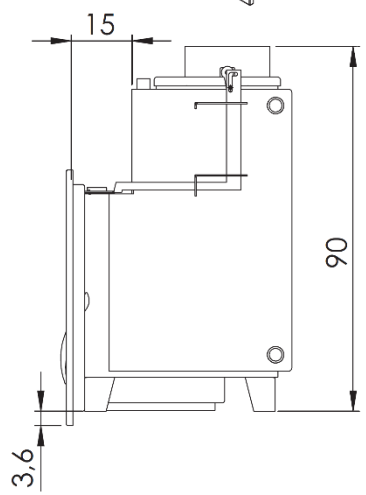
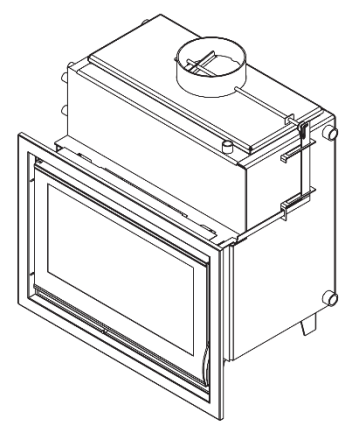
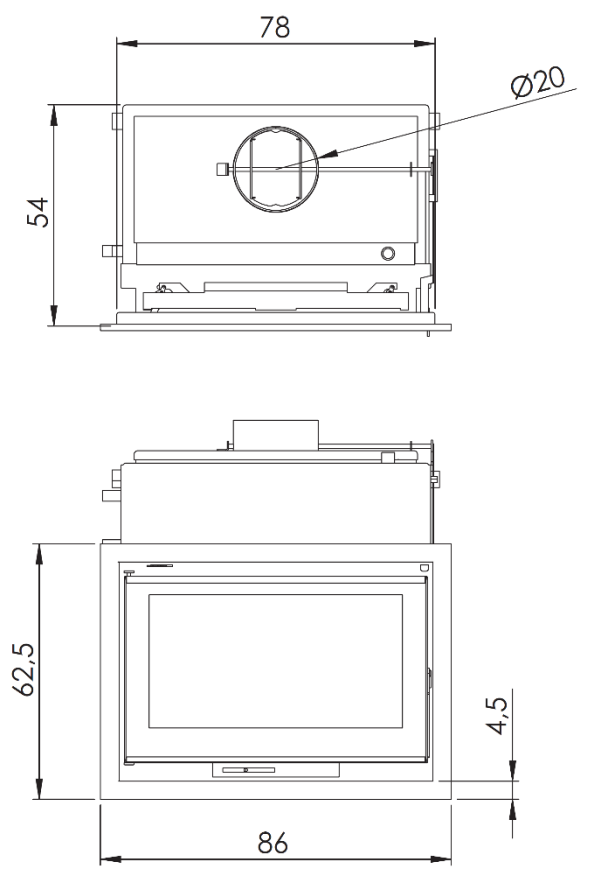

Modelo C-100 HIDRO

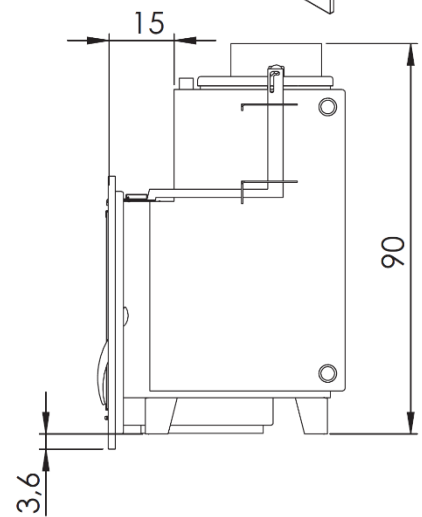
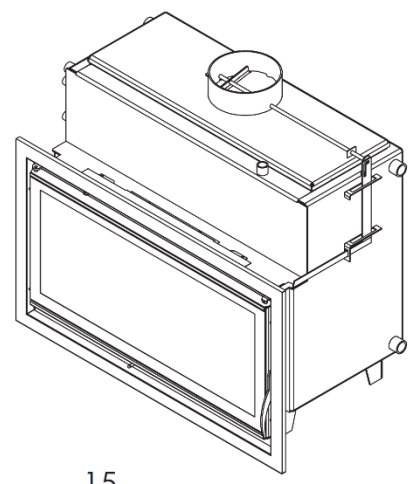
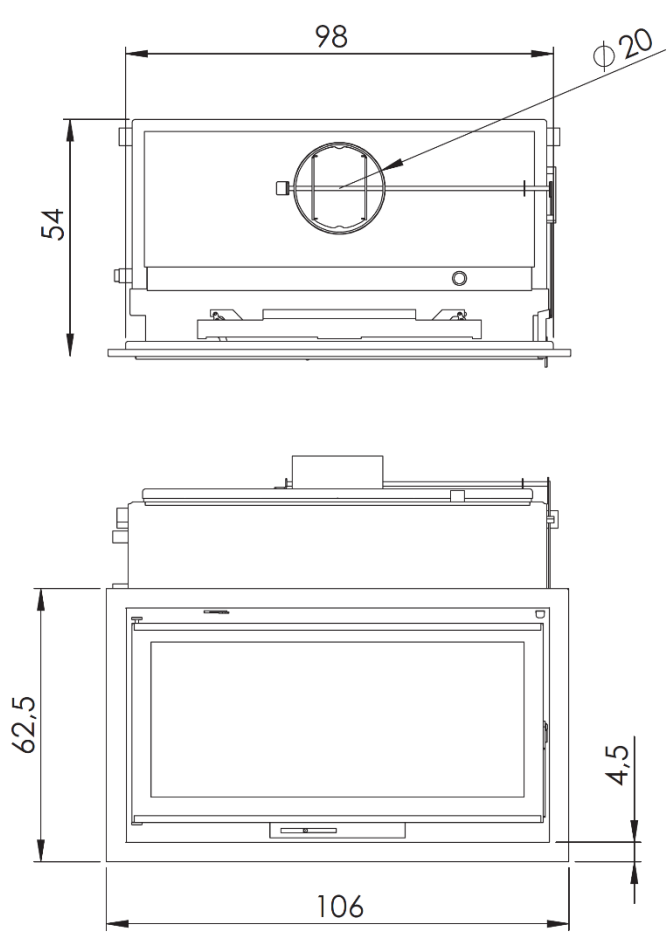



- 1 Sistema de seguridad mediante serpentín en inoxidable para descarga térmica.
- 2 Sistema cortatiros.
- 3 Regulación entrada de aire secundario.
- 4 Regulación entrada de aire primario.
- 5 Cámara de combustión revestida con paneles de acero.
- 6 Cámara de agua defletores Incluye deflector fácilmente desmontable

Detalhe da câmara de água defletora:

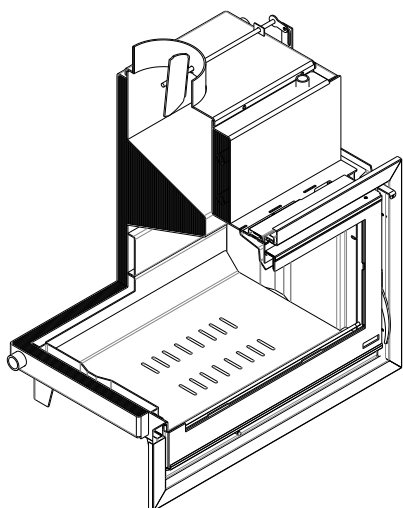
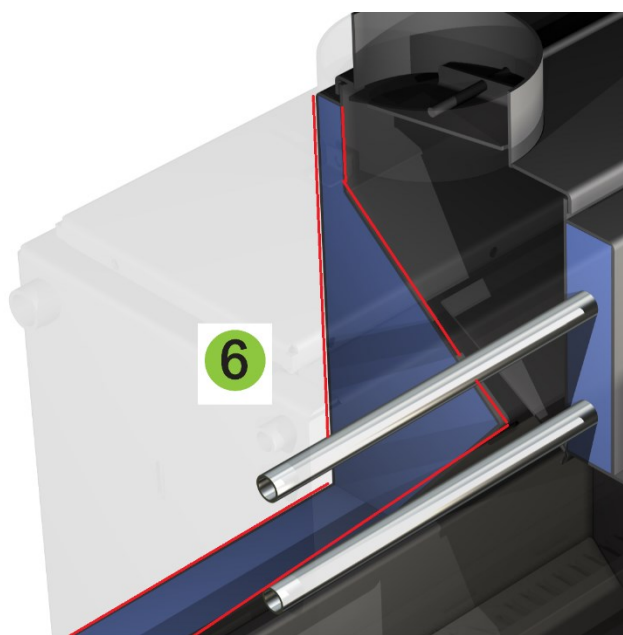

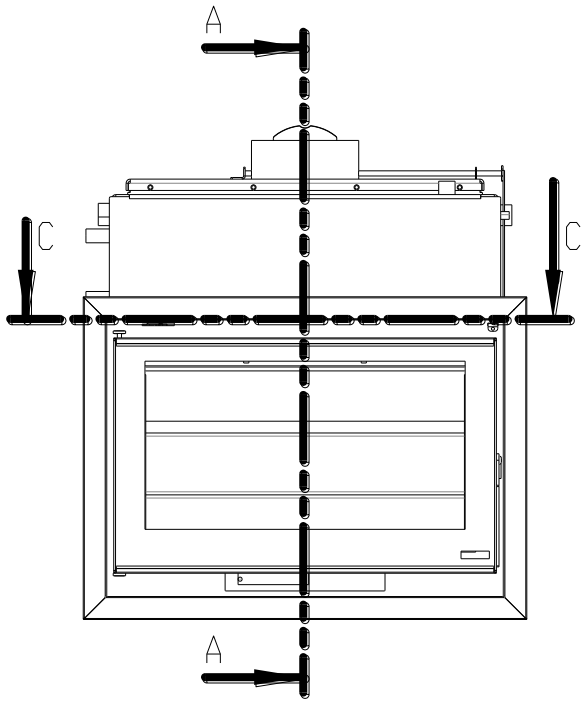

CAMARA DE AGUA

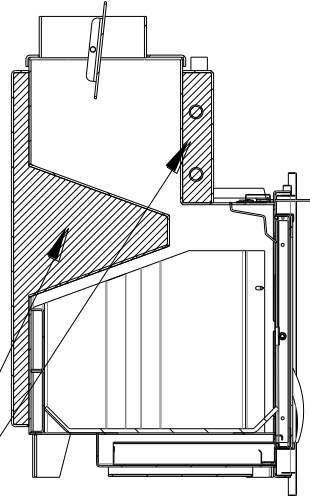

SECCIÓN A-A
ESCALA 1 : 15

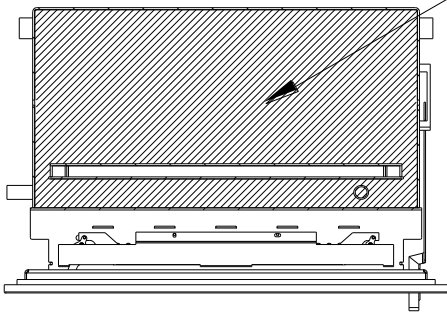

SECCIÓN C-C
ESCALA 1 : 15

